LDO voltage regulator **(output voltage value 1.0 V, 1.2 V, 1.5 V, 1.8 V)**

SPECIFICATION

1 FEATURES

- SMIC CMOS 0.18 um
- High precision stabilization voltage
- Different output voltage value (1.0V, 1.2V, 1.5V, 1.8V)
- Several operating modes
- Low current consumption
- Small area
- Output external oscillation suppression high level
- Supported foundries: TSMC, UMC, Global Foundries, SMIC, iHP, AMS, Vanguard, SilTerra

2 APPLICATION

The output voltage can be used for both analog and digital blocks. The main application:

- Portable electronic devices
- System-on-chip for different purposes
- Measurement and calibration systems
- Navigation systems
- Communication systems

3 OVERVIEW

The regulator stabilizes the external voltage and forms an output level of the specified value. Adjustment is carried out by negative feedback through the operational amplifier. CMOS-transistors keys are used for commutation of different output voltage values. Feedback allows for voltage drop on the wire by which stabilized voltage is supplied to the cell.

The block is fabricated on SMIC CMOS 0.18 um technology.

4 STRUCTURE

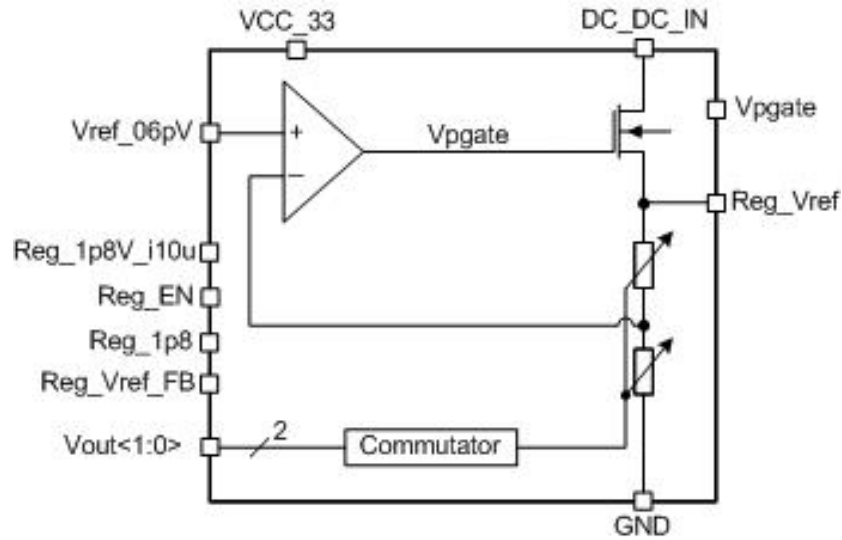

Figure 1: Voltage regulator structure

5 PIN DESCRIPTION

Name	Direction	Description
Reg_1p8V_i10u	I	Reference current 10 uA
Reg_EN	I	Enable/disable
Reg_1p8	I	Output voltage control
Reg_Vref_FB	I	Feedback output
Vout<1:0>	I	Output voltage digital code control
DC_DC_IN	I	Input for external regulator signal
Vpgate	O	External capacitor output
Vref_0p6V	O	Reference voltage
Reg_Vref	O	Output voltage
VCC33	IO	Supply voltage 3.15 V
GND	IO	Ground

6 LAYOUT DESCRIPTION

The block dimensions are given in the table 1.

Table 1: Block dimensions

Dimension	Value	Unit
Height	198.33	um
Width	116.82	um

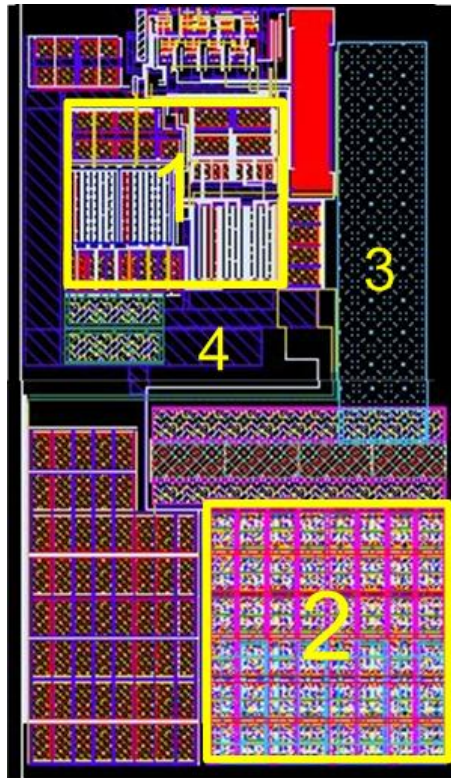

Figure 2: Device layout

1. OTA
2. Main control transistor
3. Output voltage bus
4. Ground bus

7 OPERATING CHARACTERISTICS

7.1 TECHNICAL CHARACTERISTICS

Technology _____ SMIC CMOS 0.18 um
 Status _____ silicon proven
 Area _____ 0.02 mm²

7.2 ELECTRICAL CHARACTERISTICS

The values of electrical characteristics are specified for $V_{cc} = 2.7 \div 3.6$ V and $T = -45 \div +90$ °C. Typical values are at $V_{cc} = 3.15$ V and $T = +27$ °C, unless otherwise specified.

Parameter	Symbol	Condition	Value			Unit
			min	typ	max	
Supply voltage	V_{cc}	-	2.7	3.15	3.6	V
Operating temperature range	T	-	-45	27	90	°C
Reference voltage	V_R	-	-	0.6	-	V
Voltage regulator output level	V_{ref}	$V_{out<1:0>=3}$	1.75	1.8	1.86	V
		$V_{out<1:0>=2}$	1.45	1.5	1.55	
		$V_{out<1:0>=1}$	1.16	1.2	1.24	
		$V_{out<1:0>=0}$	0.99	1	1.06	
Reference current	I_R	-	-	10	-	uA
Maximum load current	I_L	-	-	10	-	mA
Reference voltage deviation	ΔV_{ref}	-	-	3.14	-	%
Temperature error	ΔT	-	-	1.07	-	%
Current consumption (external supply voltage)	I_{cc}	-	-	13.71	14.86	uA
Current consumption (external regulator)	I_{cc_dc}	$V_{ref}=1$ V	-	14.07	-	uA
		$V_{ref}=1.2$ V		16.4		
		$V_{ref}=1.5$ V		20.47		
		$V_{ref}=1.8$ V		24.57		
Current consumption in a standby mode	I_{stb}	-	-	0.01	-	nA
Input logic-high level	V_{IH}	For digital inputs	0.7 V_{cc}	-	3.6	V
Input logic-low level	V_{IL}		-0.25	-	0.3	V

8 DELIVERABLES

Depending on license type IP may include:

- Schematic or NetList
- Abstract view (.lef and .lib files)
- Layout (optional)
- Verilog behavior model
- Extracted view (optional)
- GDSII
- DRC, LVS, antenna report
- Test bench with saved configurations (optional)
- Documentation