

LDO voltage regulator (output voltage 0 to 1.8 V)

SPECIFICATION

1 FEATURES

- iHP SiGe BiCMOS 0.25 μm
- Output voltage 0...1.8 V
- Load current 50 mA
- High precision stabilization voltage
- Low current consumption
- Small area
- High efficiency in DC/DC step down converter operating mode
- Portable to other technologies (upon request)

2 APPLICATION

- Portable electronic devices
- System-on-chip for different purposes
- Navigation systems
- Communication systems

3 OVERVIEW

Power supply voltage stabilizer converts supply voltage to voltage of the specified value and operates in two modes: DC/DC step down converter and LDO. DC/DC step down converter mode offers high efficiency over a supply voltage range (up to 85.33%). Voltage adjustment is made by switching resistive chain in feedback circuit. Voltage drop on power line is also compensated by feedback.

The block is fabricated on iHP SiGe BiCMOS 0.25 μm technology.

4 STRUCTURE

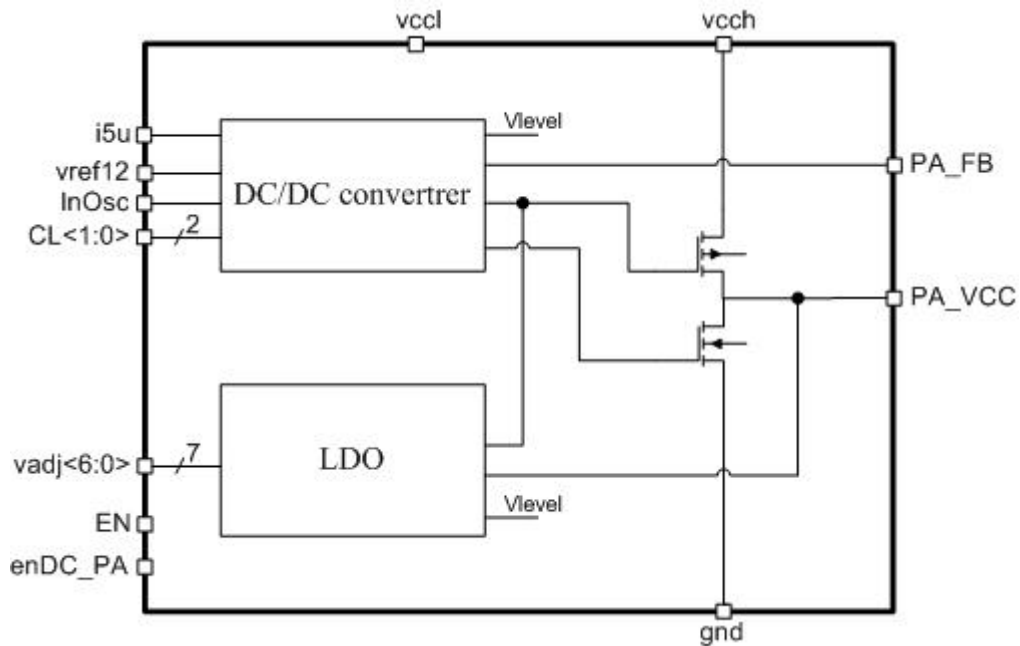

Figure 1: Power supply voltage stabilizer structure

5 PIN DESCRIPTION

Name	Direction	Description
i5u	I	Reference current (5uA)
vref12	I	Reference voltage
InOsc	I	DC/DC converter input frequency
EN	I	Enable/disable
enDC_PA	I	Enable/disable LDO / DC/DC converter step down operating mode
vadj<6:0>	I	Output voltage control
CL<1:0>	I	Current limiting control
PA_FB	I	Feedback input
PA_VCC	O	Converter output
vccl	IO	Low level supply voltage
vcch	IO	Supply voltage
gnd	IO	Ground

6 LAYOUT DESCRIPTION

The block dimensions are given in the table 1

Table 1: Block dimensions

Dimension	Value	Unit
Height	354	μm
Width	813	μm

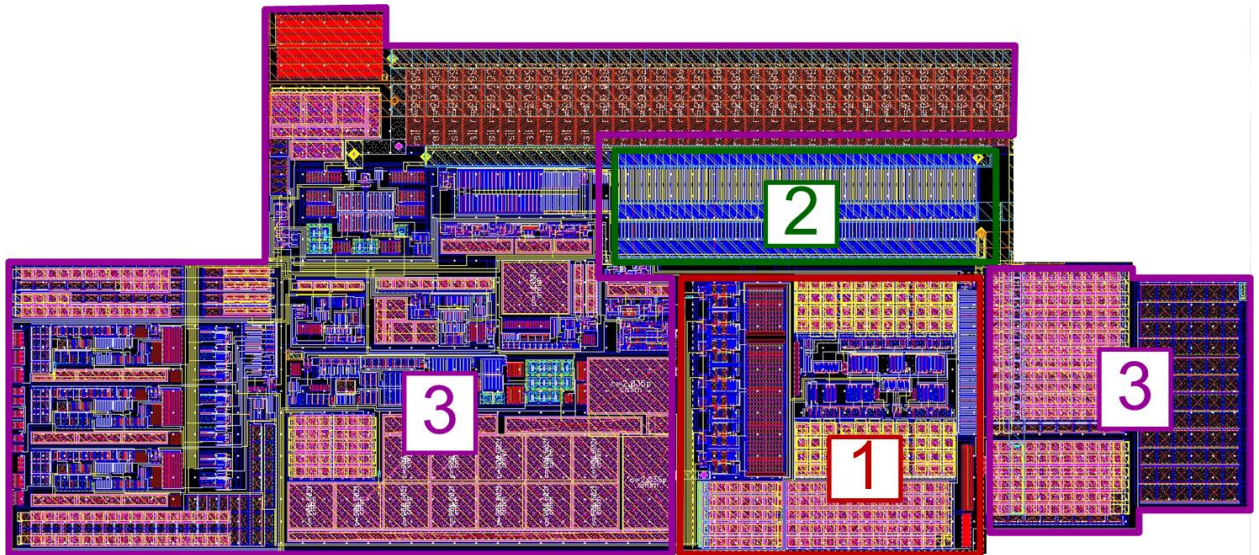

Figure 2: Power supply voltage stabilizer layout view

1. Linear regulator
2. Control element
3. DCDC converter

7 OPERATING CHARACTERISTICS

7.1 TECHNICAL CHARACTERISTICS

Technology _____ iHP SiGe BiCMOS 0.25 um
 Status _____ silicon proven
 Area _____ 0.22 mm

7.2 ELECTRICAL CHARACTERISTICS

The values of electrical characteristics are specified for $V_{cc} = 1.9 \div 2.7$ V and $T_j = -45 \div +85^\circ\text{C}$. Typical values are at $V_{cc} = 2.05$ V and $T_j = +27^\circ\text{C}$, unless otherwise specified.

Parameter	Symbol	Condition	Value			Unit
			min	typ	max	
Supply voltage	V_{cc}	-	9	2.05	2.7	V
Operating temperature range	T_j	-	-45	27	85	$^\circ\text{C}$
Reference voltage	V_R	-	-	-	-	V
Output voltage	V_{Out}	-	0	-	1.58	V
DC/DC converter operating frequency	F_{IN}	mV	-	515	-	kHz
		mV	-	172	-	
Reference current	I_R	-	-	5	-	μA
Maximum load current	I_L	-	-	50	-	mA
Current consumption	I_{LDO}	LDO operating mode	-	143	-	μA
Current consumption	$I_{DC/DC}$	DC/DC operating mode	-	188	-	μA
Current consumption in a standby mode	I_{stb}	-	-	-	-	nA
Output voltage tuning interval	dV	$v_{cc1}=1.8$ V	-	14	-	mV
DC/DC converter duty cycle	DC	-	7	-	95	%
DC/DC converter efficiency	$\eta_{DC/DC}$	$=1.56$ V $I_L=40$ mA	-	-	-	%
LDO converter efficiency	η_{LDO}	$=1.56$ V $I_L=40$ mA	57.04	-	81.73	%
Input logic-high level	V_{IH}	For digital inputs	$0.7V_{cc}$	-	$V_{cc}+0.25$	V
Input logic-low level	V_{IL}		-0.25	-	$0.3V_{cc}$	V

8 DELIVERABLES

Depending on license type IP may include:

- Schematic or NetList
- Layout or blackbox
- Verilog, lef and lib files
- Extracted view (optional)
- GDSII
- DRC, LVS, antenna report
- Test bench with saved configurations (optional)
- Documentation

REVISION HISTORY

From version 1.1:

- Section 3
- Subsection 7.2 update