

Baseband LNA

SPECIFICATION

1 FEATURES

- TSMC CMOS 65 nm
- Wide frequency band
- High linearity
- Wide gain tuning range
- Linear (in dB scale) gain step with digital control
- 50 Ω input impedance matching using one transformer
- Automatic offset compensation
- Supported foundries: TSMC, UMC, Global Foundries, SMIC

2 APPLICATION

- Front-end LF signal amplification in receivers

3 OVERVIEW

BB LNA is used to amplify signal from the radio receiver input in band up to 150 MHz. LNA has a low noise figure, high linearity and wide gain tuning range.

BB LNA consists of three stages. Each stage is a linear differential amplifier. Input impedance of amplifier with transformer 1:3 is 50 Ω . BB LNA has an offset compensation block.

4 STRUCTURE

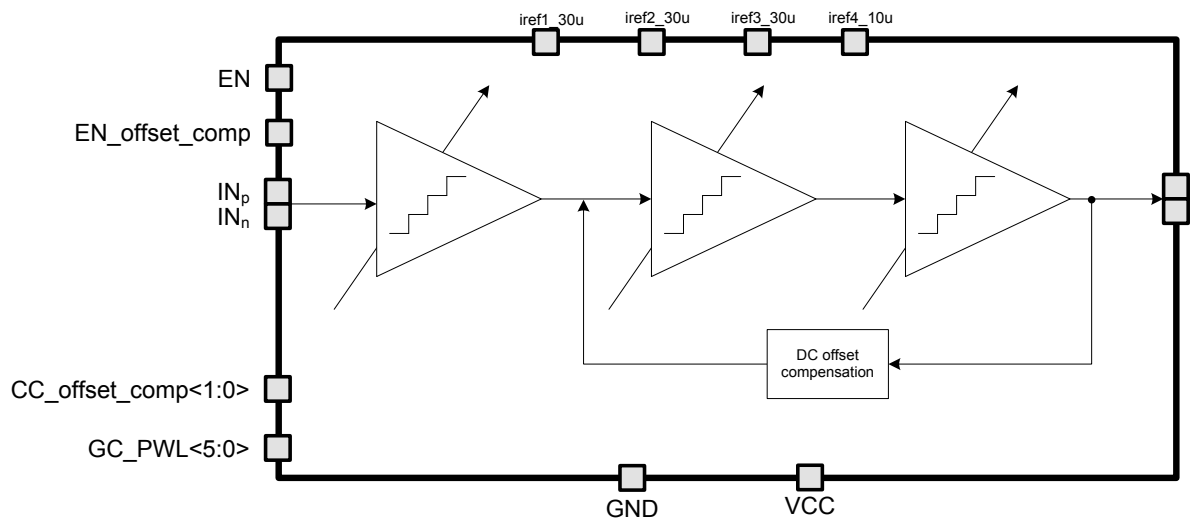

Figure 1: Baseband LNA structure.

5 PIN DESCRIPTION

Name	Direction	Description
iref1_30u	IO	Amplifier input stage reference current 30 μ A
iref2_30u	IO	Amplifier second stage reference current 30 μ A
iref3_30u	IO	Amplifier output stage reference current 30 μ A
iref4_10u	IO	Offset compensation reference current 10 μ A
EN	I	BB LNA enable/disable
EN_offset_comp	I	Offset compensation enable/disable
INp	I	BB LNA differential input
INn	I	
GC_PWL<5:0>	I	Gain control:
CC_offset_comp<1:0>	I	Offset compensation cutoff frequency control
OUTp	O	BB LNA differential output
OUTn	O	
VCC	IO	Supply voltage
GND	IO	Ground

6 LAYOUT DESCRIPTION

The block dimensions are given in the table 1.

Table 1: Block dimensions.

Dimension	Value	Unit
Height	300	μm
Width	1430	μm

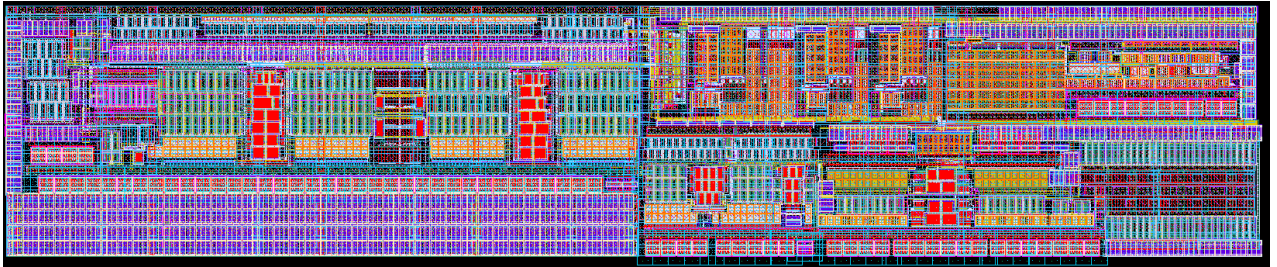

Figure 2: LNA layout view.

7 OPERATING CHARACTERISTICS

7.1 TECHNICAL CHARACTERISTICS

Technology _____ TSMC CMOS CRN65LP
 Status _____ silicon proven
 Area _____ 0.44mm²

7.2 ELECTRICAL CHARACTERISTICS

The values of electrical characteristics are specified for $V_{cc} = 2.375 \div 2.625$ V and $T = -40 \div 125$ °C. Typical values are at $V_{cc} = 2.5$ V, $T = 85$ °C, unless otherwise specified.

Parameter	Symbol	Condition	Value			Unit
			min	typ	max	
Supply voltage	V_{cc}	-	2.375	2.5	2.625	V
Operating temperature range	T	-	-40	+85	+125	°C
Frequency range	F_c	-	0.1	-	150	MHz
Gain	G	-	-22.3	-	+35.0	dB
Third order intermodulation	IM3	$G=+35.0$ dB $P_{out} = -20$ dBm	-	-61.1	-55.3	dB
Noise figure	NF	$G=+35.0$ dB	-	-	5	dB
Current consumption	I_{cc}	-	110	120	130	mA
Stand-by current	I_{stb}	-	-	-	3	uA
Input logic-level high	V_{IH}	-	$0.8V_{cc}$	-	V_{cc}	V
Input logic-level low	V_{IL}	-	0	-	$0.2V_{cc}$	V

8 TYPICAL CHARACTERISTICS

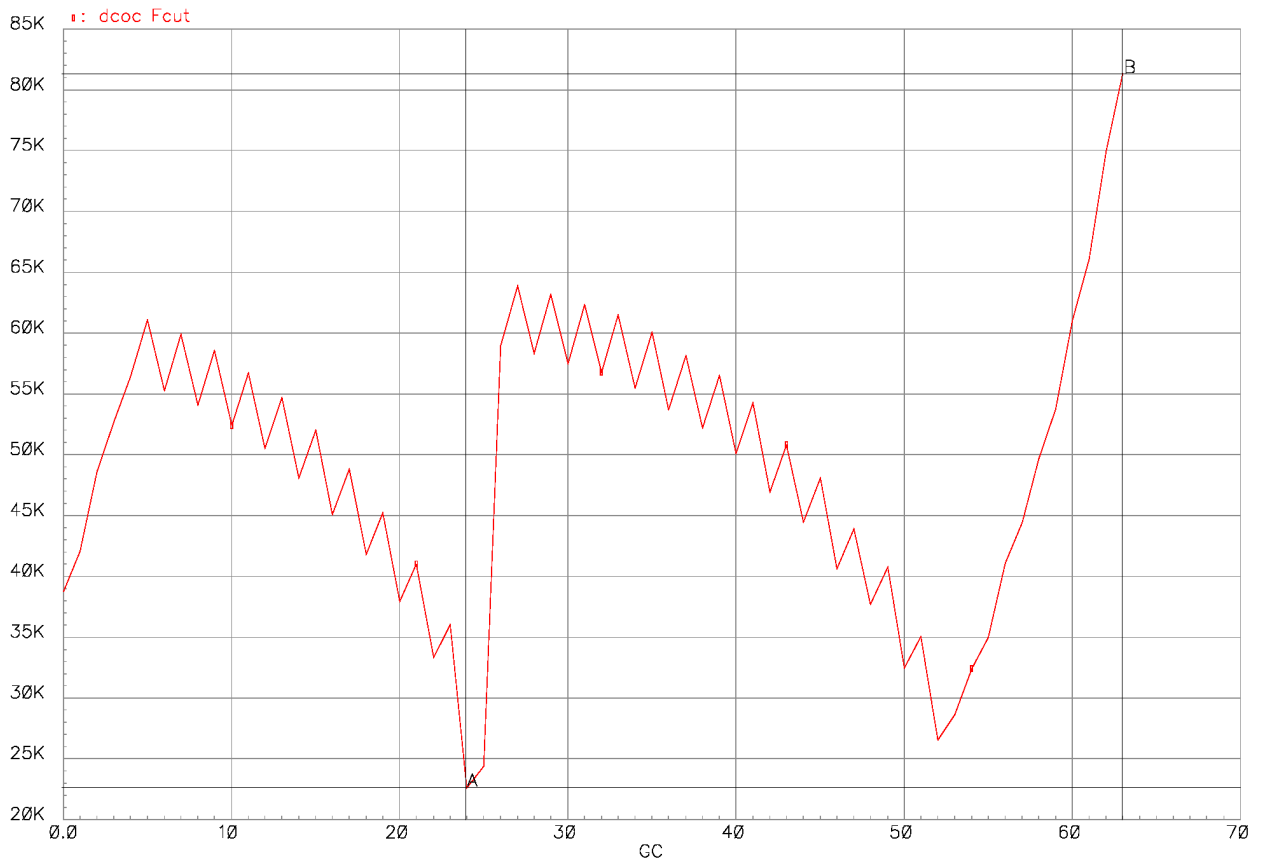

Figure 3: Offset compensation cut-off frequency vs gain.

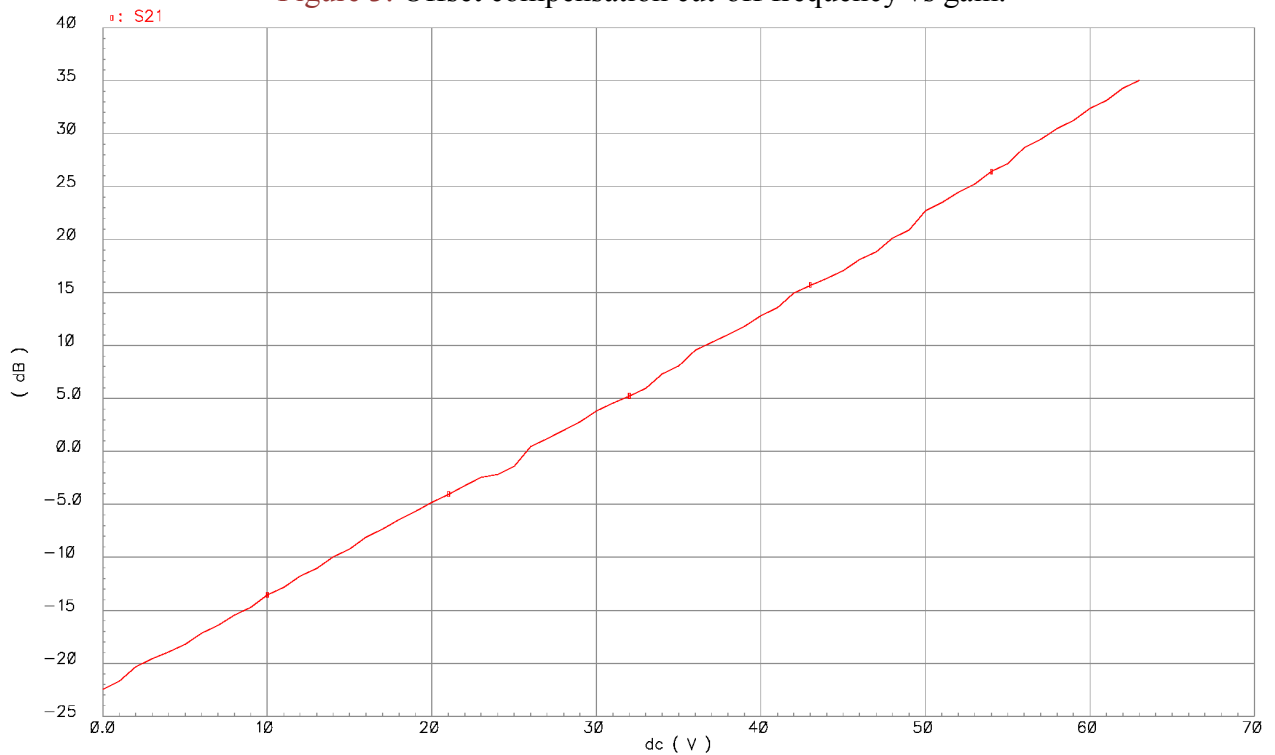

Figure 4: Gain vs control code.

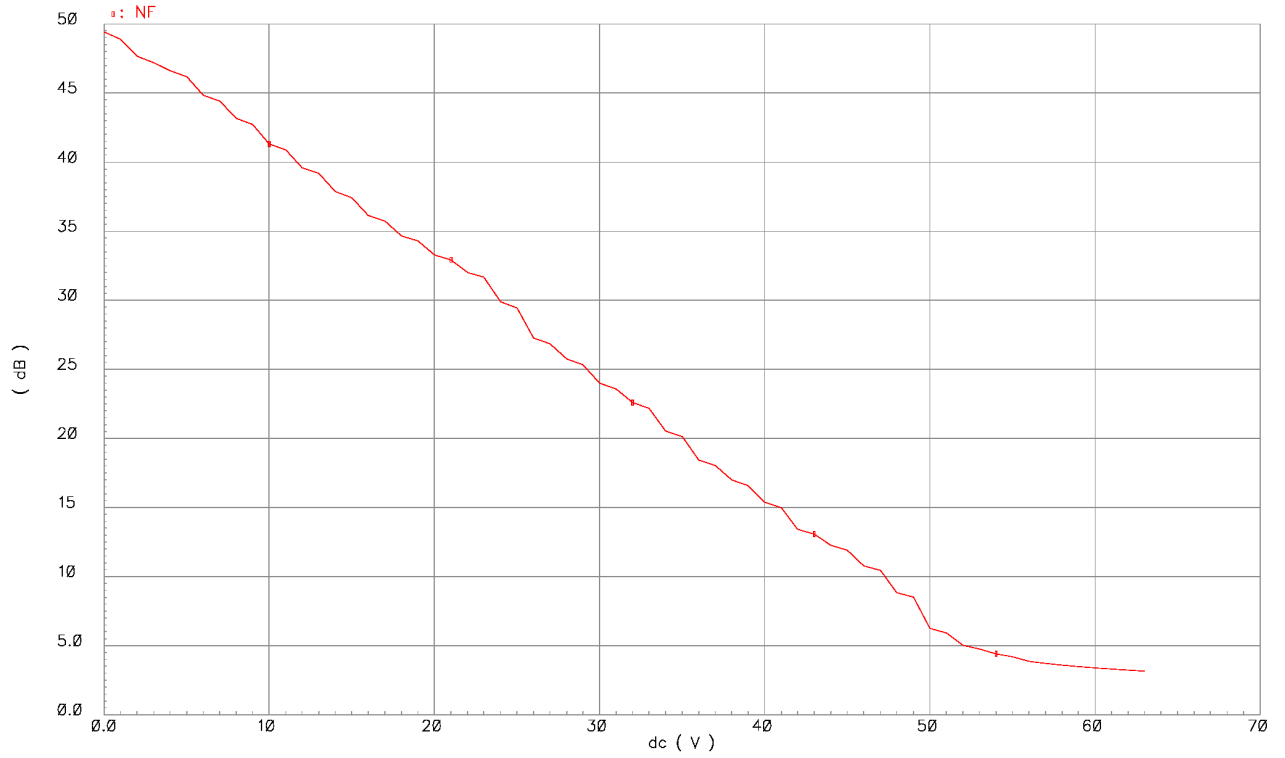

Figure 5: Noise figure vs control code.

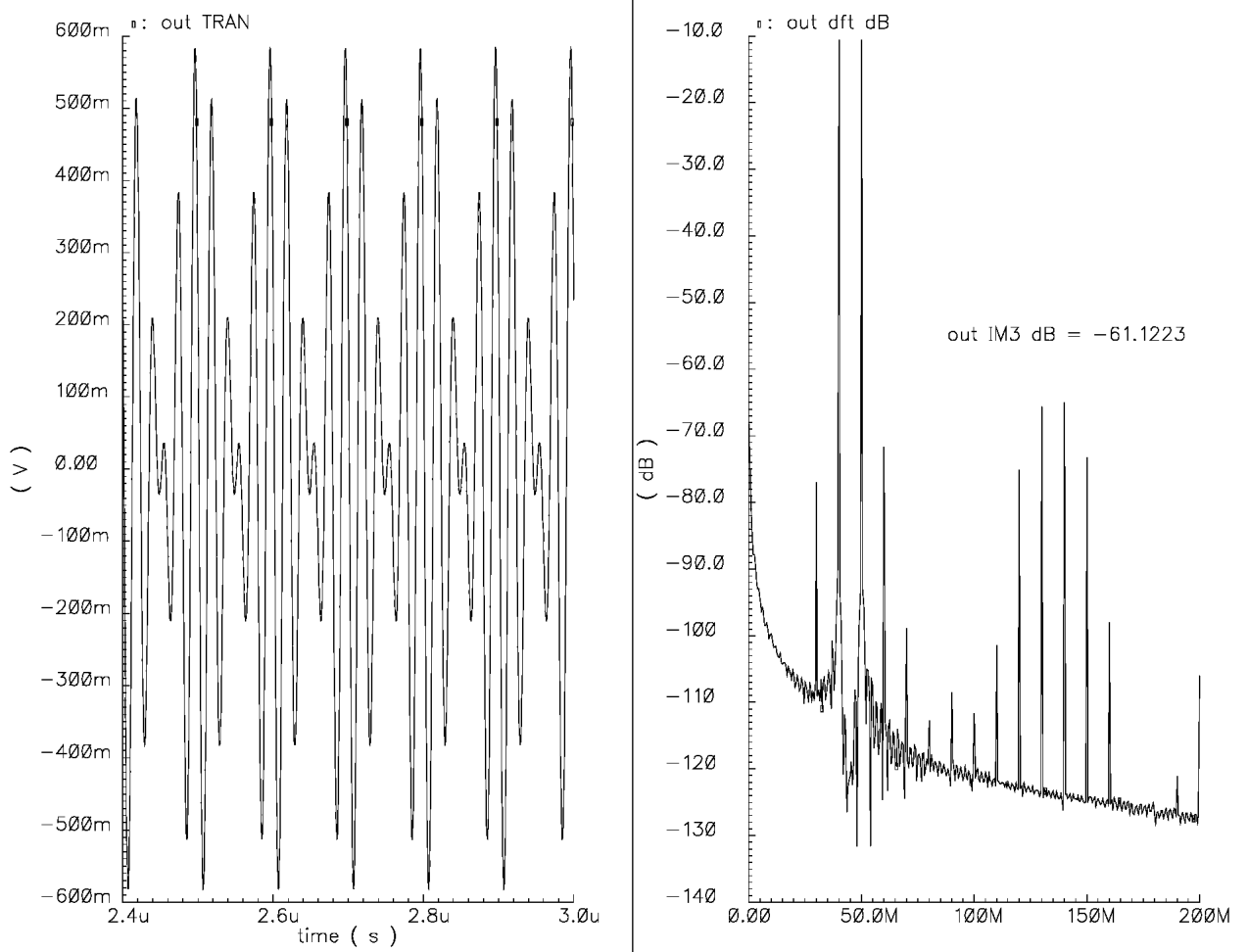

Figure 6: Third order intermodulation.

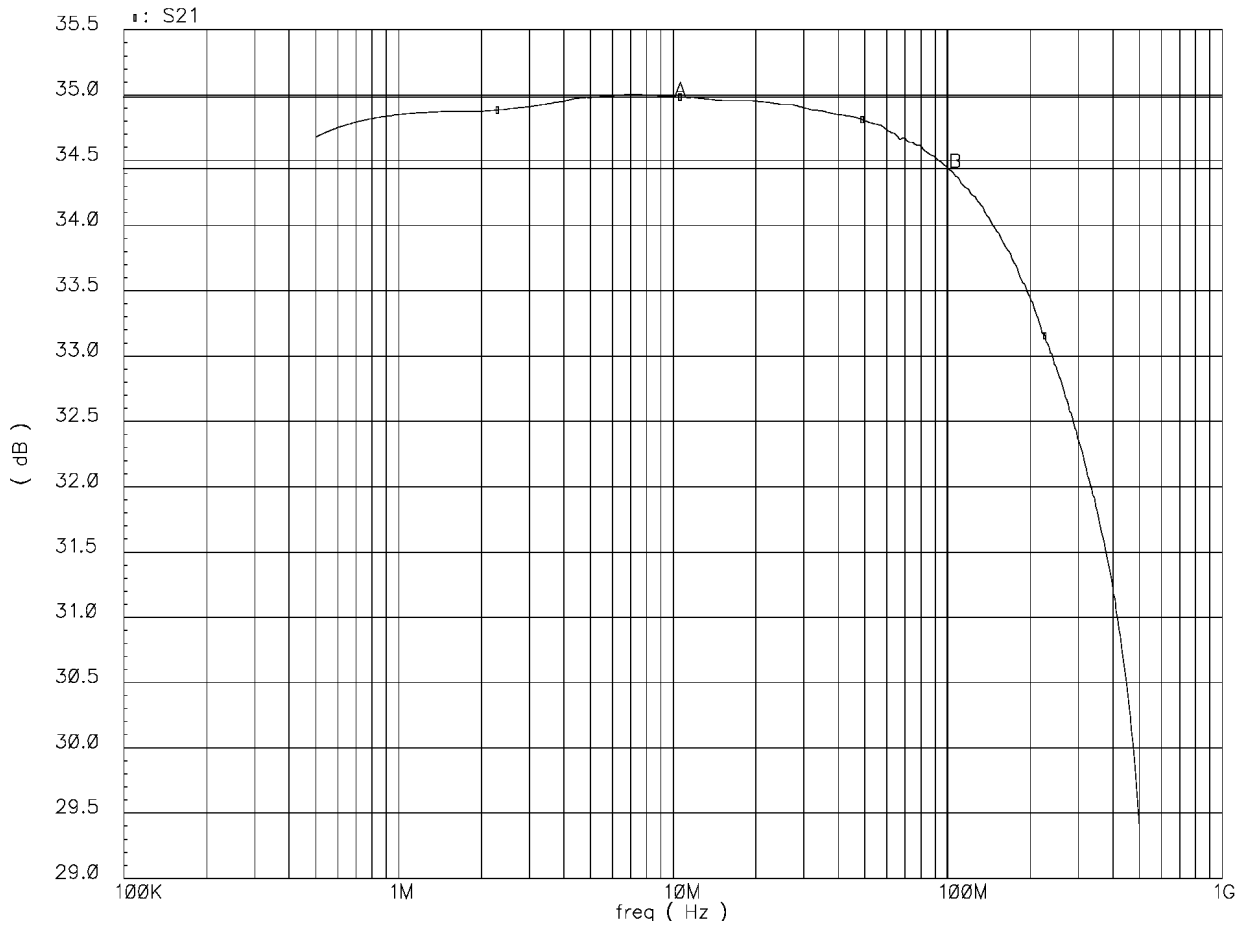

Figure 7: Frequency response.

9 DELIVERABLES

IP contents:

- Schematic or NetList
- Layout or blackbox
- Extracted view (optional)
- GDSII
- DRC, LVS, antenna report
- Test bench with saved configurations (optional)
- Documentation