

## Bandgap voltage reference

---

### SPECIFICATION

#### 1 FEATURES

- SMIC CMOS 0.18 $\mu$ m
- Output voltage 1.2 V
- Temperature-compensated voltage in a wide temperature range
- Low current consumption
- Small area
- Bipolar diode characteristics control
- Supported foundries: TSMC, UMC, Global Foundries, SMIC, iHP, AMS, Vanguard, SilTerra

#### 2 APPLICATION

The output reference voltage can be used for both analog and digital blocks. The main application:

- Supply voltage stabilization systems
- Comparison and detection systems
- System-on-chip for different purposes
- Measurement and calibration systems
- Technological research of microelectronic components
- Navigation systems

#### 3 OVERVIEW

Bandgap voltage reference forms temperature-compensated voltage level equal to the width of the band gap of silicon due to mutual compensation of temperature dependence of bipolar diodes and resistors.

The block is fabricated on SMIC CMOS 0.18 $\mu$ m technology.

## 4 STRUCTURE

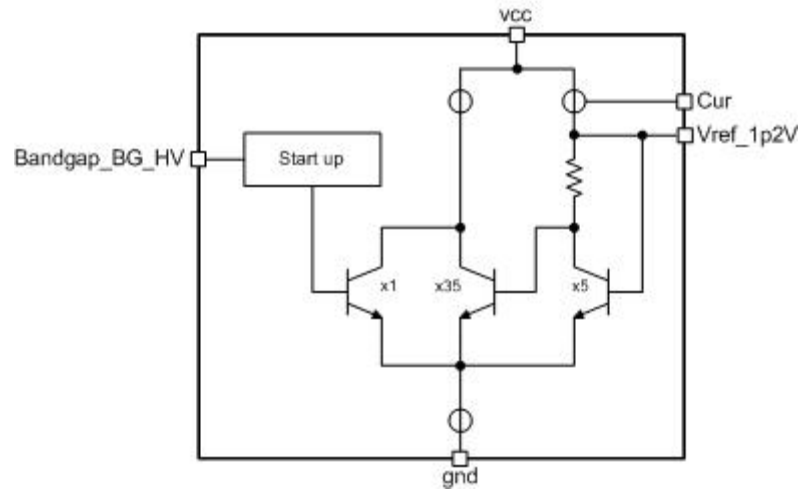

Figure 1: Bandgap voltage reference structure.

## 5 PIN DESCRIPTION

Name	Direction	Description
Bandgap_BG_HV	I	Enable/ disable
Cur	O	Current rise
Vref_1p2V	O	Reference voltage
vcc	IO	Supply voltage
gnd	IO	Ground

## 6 LAYOUT DESCRIPTION

The block dimensions are given in the table 1.

**Table 1:** Block dimensions.

Dimension	Value	Unit
Height	198.0	$\mu\text{m}$
Width	243.54	$\mu\text{m}$

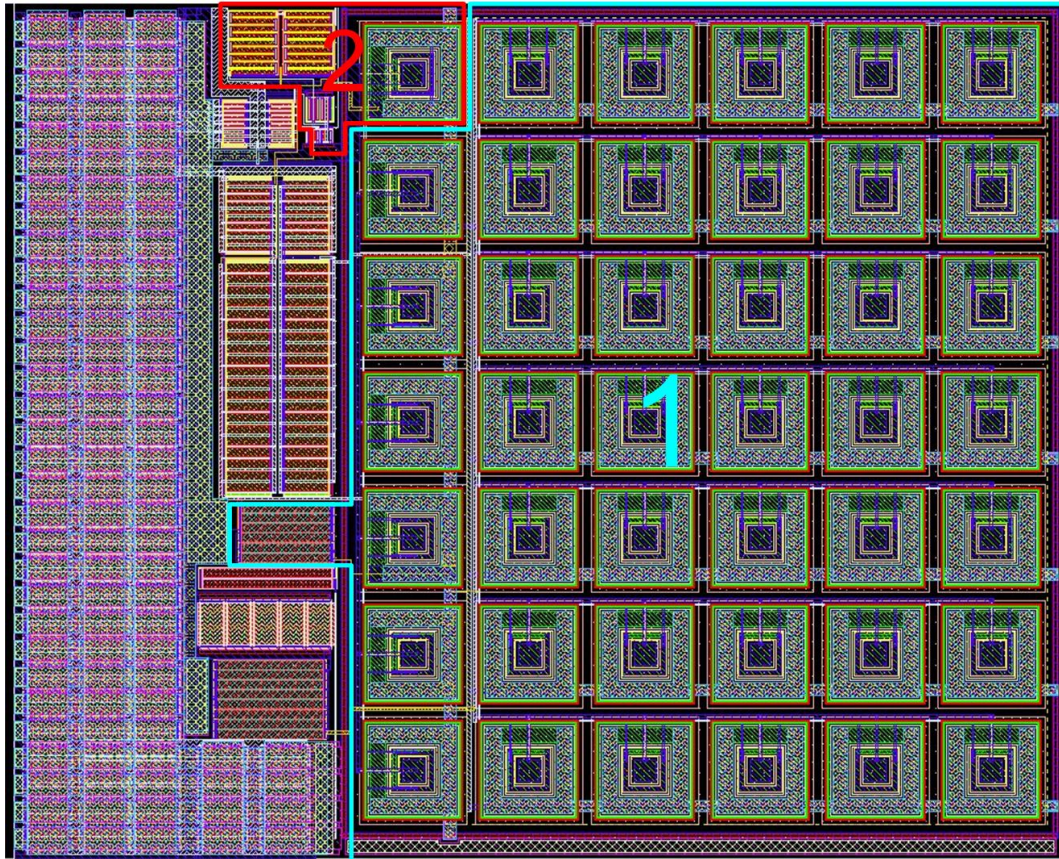

**Figure 2:** Device layout view.

1. Temperature-compensated reference voltage source bipolar base
2. Start up circuit

## 7 OPERATING CHARACTERISTICS

### 7.1 TECHNICAL CHARACTERISTICS

Technology \_\_\_\_\_ SMIC CMOS 0.18 $\mu$ m  
 Status \_\_\_\_\_ silicon proven  
 Area \_\_\_\_\_ 0.05mm<sup>2</sup>

### 7.2 ELECTRICAL CHARACTERISTICS

The values of electrical characteristics are specified for  $V_{cc} = 2.7 \div 3.6$  V and  $T = -45 \div +90$  C. Typical values are at  $V_{cc} = 3.15$  V and  $T = +27^\circ$  C, unless otherwise specified.

Parameter	Symbol	Condition	Value			Unit
			min	typ	max	
Supply voltage	$V_{cc}$	-	2.7	3.15	3.6	V
Operating temperature range	T	-	-45	27	90	$^\circ$ C
Reference voltage	$V_{ref}$	-	1.16	1.19	1.23	V
Current consumption	$I_{cc}$	-	-	17.78	26.10	$\mu$ A
Current consumption in a standby mode	$I_{stb}$	-	-	0.01	-	nA
Reference voltage deviation	$\Delta V_{ref}$	-	-	3.17	-	%
Temperature error	$\Delta T$	-	-	0.71	-	%
Input logic-high level	$V_{IH}$	For digital inputs	$0.7 V_{cc}$	-	3.6	V
Input logic-low level	$V_{IL}$		-0.25	-	0.3	V

## 8 DELIVERABLES

IP contents:

- Schematic or NetList
- Layout or blackbox
- Extracted view (optional)
- GDSII
- DRC, LVS, antenna report
- Test bench with saved configurations (optional)
- Documentation