

Reference current and voltage source

SPECIFICATION

1 FEATURES

- iHP SiGe BiCMOS 0.25 μm
- Output current termocompensation in wide temperature range
- Built-in battery low power indicator
- Low power consumption in power-saving mode (optional)
- Small area

2 APPLICATION

- Supply voltage stabilization systems
- Comparison and detection systems
- System-on-chip for different purposes

3 OVERVIEW

Reference current and voltage source is used to supply any analog blocks. It is based on the reference voltage source forming temperature compensation voltage and two voltage-to-current converters. The first converter uses an external resistor and output current is characterized by weak dependence on temperature. The second converter uses an internal resistor and output current is characterized by temperature and process parameters which are matched to the internal resistor. The battery low power indicator consists of a comparator which is based on two-stage operational amplifiers.

The block is fabricated on iHP SiGe BiCMOS 0.25 μm technology.

4 STRUCTURE

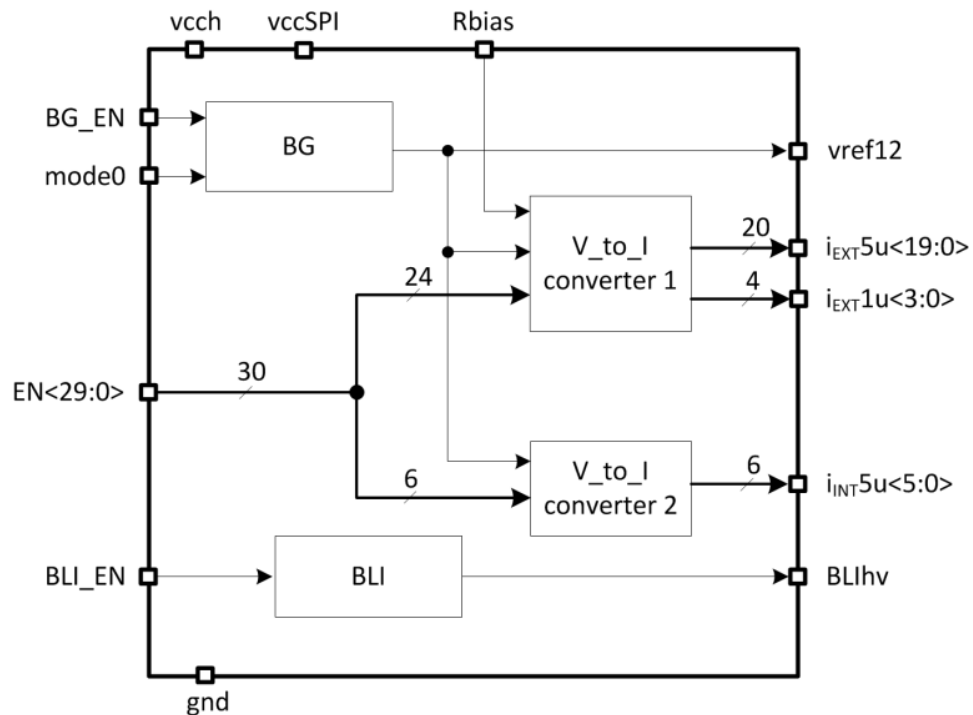

Figure 1: Reference current and voltage source structure.

5 PIN DESCRIPTION

Name	Direction	Description
BG_EN	I	Reference current and voltage source enable
mode0		
EN<29:0>	I	Enable/disable
BLI_EN	I	Battery low power indicator enable
Rbias	IO	Output external resistor
BLIhv	O	Battery low power indicator output: "0" charged "1" uncharged
vref12	O	Reference voltage
i_EXT5u<19:0>	O	Output reference current (5 uA, external resistor)
i_INT5u<5:0>	O	Output reference current (5 uA, internal resistor)
i_EXT1u<3:0>	O	Output reference current (1 uA, external resistor)
vcch	IO	Supply voltage
vccSPI	IO	
gnd	IO	Ground

6 LAYOUT DESCRIPTION

The block dimensions are given in the table 1.

Table 1: Block dimensions.

Dimension	Value	Unit
Height	279	um
Width	731	um

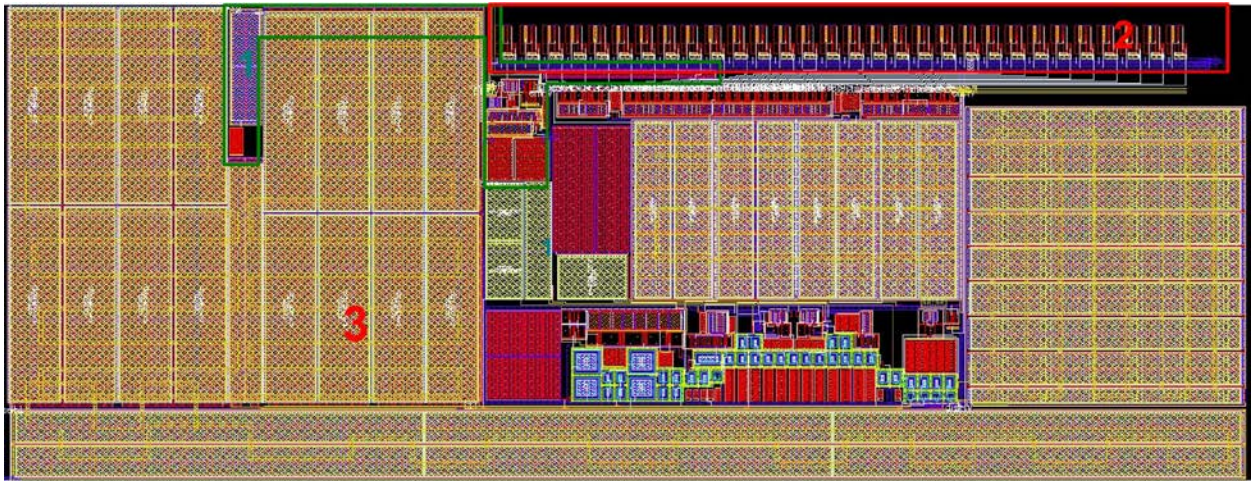

Figure 2: Device layout view.

1. Battery low power indicator
2. Switch blocks
3. Reference current and voltage former

7 OPERATING CHARACTERISTICS

7.1 TECHNICAL CHARACTERISTICS

Technology _____ iHP SiGe BiCMOS 0.25 um
 Status _____ silicon proven
 Area _____ 0.21mm²

7.2 ELECTRICAL CHARACTERISTICS

The values of electrical characteristics are specified for $v_{cch} = v_{ccSPI} = 1.09 \div 3.5$ V and $T_a = -45 \div +85$ °C. Typical values are at $v_{cch} = v_{ccSPI} = 2.05$ V, $T_a = +27$ °C, unless otherwise specified.

Parameter	Symbol	Condition	Value			Unit
			min	typ	max	
Supply voltage	v_{cch}	-	1.09	2.05	3.5	V
	v_{ccSPI}	-	1.09	2.05	3.5	
Operating temperature range	T_a	-	-45	27	85	°C
Reference voltage	V_{ref}	-	1.16	1.18	1.19	V
Reference voltage deviation	ΔV_{ref}	-	-	-	1.1	%
Temperature error	ΔT	-	-	-	1	%
Output current reference	I_{INT5u}	For output $i_{INT5u}<5:0>$ internal resistor	4.45	5.02	5.65	uA
	I_{EXT5u}	For output $i_{EXT5u}<19:0>$ external resistor	5	5.1	5.2	uA
	I_{EXT1u}	For output $i_{EXT1u}<3:0>$ external resistor	1	1.02	1.04	uA
Current consumption	I_{cc}	-	-	60	70	uA
Current consumption in a power-saving mode	I_{stb}	-	-	4	7	uA
Input logic-high level	V_{IH}	For digital inputs	$0.7V_{cc}$	-	$V_{cc}+0.25$	V
Input logic-low level	V_{IL}		-0.25	-	0.3	V

8 DELIVERABLES

IP contents:

- Schematic or NetList
- Layout or blackbox
- Extracted view (optional)
- GDSII
- DRC, LVS, antenna report
- Test bench with saved configurations (optional)
- Documentation