

Voltage-controlled oscillator

SPECIFICATION

1 FEATURES

- TSMC018 SiGe
- Low phase noise
- Wide frequency range
- Adjustable output amplitude
- Low current consumption
- Supported foundries: TSMC, UMC, Global Foundries, SMIC, iHP, AMS, Vanguard, SiTerra

2 APPLICATION

- Phase-locked loop synthesizer

3 OVERVIEW

Voltage-controlled oscillator (VCO) is the generator that can be tuned over a wide range of frequencies by applying a control voltage to it (V_{ctrl}).

Frequency tuning range (2596...3678 MHz) is defined by a control voltage of a built-in switched capacitor sections, and the built-in varicap is used for a fine adjustment.

The block is fabricated on TSMC018 SiGe technology.

4 STRUCTURE

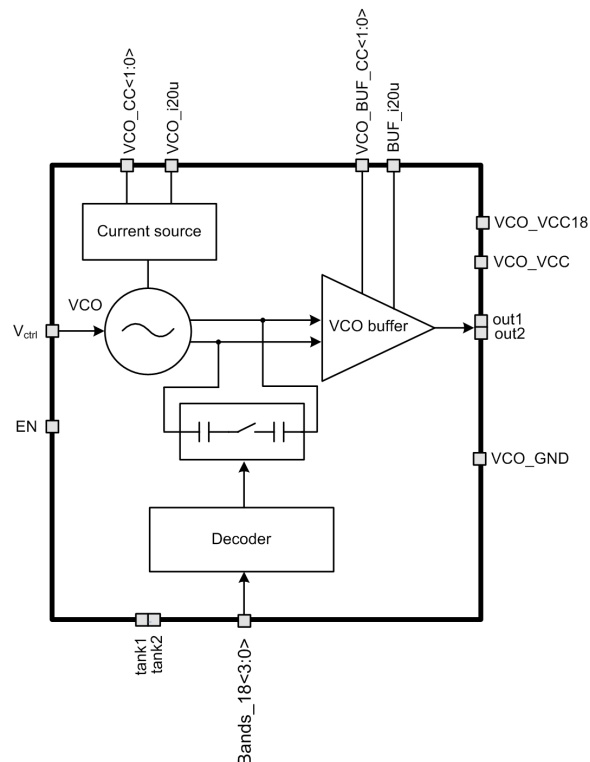

Figure 1: Voltage-controlled oscillator structure.

5 PIN DESCRIPTION

Name	Direction	Description
VCO_i20u	IO	VCO reference current
BUF_i20u	IO	VCO output buffer current
V _{ctrl}	I	Control voltage
EN	I	VCO enable/disable
Bands_18<3:0>	I	Digital code defined a subband selection
VCO_BUF_CC<1:0>	I	VCO output buffer current consumption control
VCO_CC<1:0>	I	VCO current consumption control
tank1	O	VCO differential output, unused
tank2	O	
out1	O	VCO output buffer differential output
out2	O	
VCO_VCC18	IO	Supply voltage 1.8 V
VCO_VCC	IO	Supply voltage 3 V
VCO_GND	IO	Ground

6 LAYOUT DESCRIPTION

Voltage controlled oscillator dimensions are given in the table 1.

Table 1: Block dimensions.

Dimension	Value	Unit
Height	803	μm
Width	335	μm

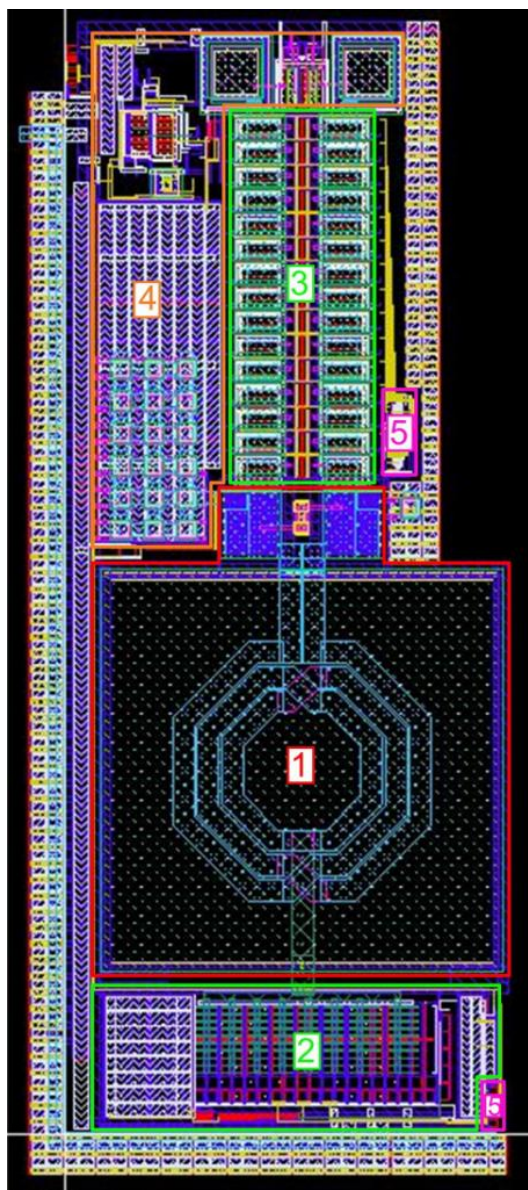

Figure 2: VCO layout view.

1. VCO core
2. Current source
3. Band cells
4. VCO buffer
5. Decoder

7 OPERATING CHARACTERISTICS

7.1 TECHNICAL CHARACTERISTICS

Technology _____ TSMC018 SiGe
 Status _____ silicon proven
 Area _____ 0.28 mm²

7.2 ELECTRICAL CHARACTERISTICS

The values of electrical characteristics are specified for $V_{cc_3.0v} = 2.8 \div 3.6$ V, $V_{cc_1.8v} = 1.6 \div 2.0$ V and $T = -40 \div +85^{\circ}\text{C}$. Typical values are at $V_{cc_3.0v} = 3.15$ V, $V_{cc_1.8v} = 1.8$ V and $T = +27^{\circ}\text{C}$., unless otherwise specified.

Parameter	Symbol	Condition	Value			Unit
			min	typ	max	
Supply voltage	$V_{cc_1.8v}$	-	1.6	1.8	2.0	V
	$V_{cc_3.0v}$		2.8	3.15	3.6	
Operating temperature range	T	-	-40	+27	+85	$^{\circ}\text{C}$
VCO frequency tuning range	F	Min. frequency	-	2596	2868	MHz
		Max. frequency	3445	3678	-	MHz
Phase noise	NF	100 KHz	-	-94	-	dBm/Hz
		1 MHz	-	-115	-	
Control voltage	V_{ctrl}	-	0.3	-	2.6	V
Tuning sensitivity	K	$V_{ctrl} = 1$ V	-	74	-	MHz/V
Adjustable output amplitude	$A_{out\ p-p}$	Differential output	400	-	-	mV
Supply current	I_{cc}	-	2.99	3.67	4.61	mA
Stand-by current	I_{stb}	-		5	100	nA
Input logic-level high	V_{IH}	For digital inputs	$0.7V_{cc_3.0v}$	-	$V_{cc_3.0v}+0.25$	V
Input logic-level low	V_{IL}		-0.25	-	0.3	V

8 DELIVERABLES

IP contents:

- Schematic or NetList
- Layout or blackbox
- Extracted view (optional)
- GDSII
- DRC, LVS, antenna report
- Test bench with saved configurations (optional)
- Documentation